

# INSTRUCTION MANUAL

## **840 Transmitter**

Loop Powered Dissolved Oxygen Transmitter



# Contents

Contents.....2

Introduction.....3

Range and Display Settings.....4

Installation.....5

*Electrical Installation*.....6

Calibration.....7

EasyCal.....8

Maintenance.....9

Spare Parts.....11

Technical Specification.....12

Technical Support.....13

**Partech (Electronics) Ltd**  
 Charlestown, St Austell  
 Cornwall, PL25 3NN, UK

Phone: +44 (0) 1726 879800  
 Fax: +44 (0) 1726 879801

email: [sales@partech.co.uk](mailto:sales@partech.co.uk) website: [www.partech.co.uk](http://www.partech.co.uk)

Issue: 2  
 Issue Date: 20th July 2010

Document Reference: 185990IM

Authorised: .....

## **Introduction**

### **General**

The 840 Transmitter is an easy-to use and reliable dissolved oxygen meter. It is specially suited for use in waste water treatment plants where lower levels of dissolved oxygen are to be measured under dirty conditions, but can also be used anywhere that dissolved oxygen is to be measured.

The 840 Transmitter consists of a probe with separate transmitter with display and calibration facilities, and has a number of notable characteristics:

- It is a true 2-wire current loop (4-20 mA) system that regulates the current in the circuit between 4 and 20 mA according to the oxygen concentration.
- Calibration is always performed to the same calibration value - tables are NOT needed.
- For a 2-minute total calibration time use the EasyCal attachment and calibrate in air saturated water instead of in the air.
- Wide choice of measurement range - either mg/l (ppm) or % sat. The user can change the range setting.
- The probe is maintenance free under normal conditions, only requiring that the membrane be kept reasonably clean to ensure consistent, accurate measurements.
- The membrane is virtually unbreakable, but should a sharp object damage it a total probe renovation can be performed in a couple of minutes using parts delivered with the unit.
- The 4-20 mA output circuit is completely galvanically isolated from the probe, there is no galvanic connection between the 4-20 mA and the fluid the probe is immersed in.

The Probe consists of an upper part with cathode, anode and temperature compensation sensor, and a cap with membrane and electrolyte.

The Transmitter is a small box with display, calibration adjustment and flat foil CAL pushbutton. As an option the Model 840 can be ordered fitted with display back-light.

### **Manual Conventions**

This manual has been written on the basis that the user has a basic knowledge of instrumentation and an understanding of the type of measurement being made. Training in the use of the 840 Transmitter can be provided by Partech, please contact sales for further information.

## Range and Display Settings

The range setting of the 840 Transmitter can be changed by the user by inserting or removing a number of jumpers as shown in the drawing at the end of the manual.

Probes for use with the 0-40 ppm (mg/l) or 0-400% saturation ranges are manufactured specially for use with high oxygen concentrations. If your system is fitted with such a probe it is NOT advisable to select the lower ranges.

It is also NOT advisable to use a standard (low oxygen concentration) probe above 20 ppm (mg/l) or 200% saturation.

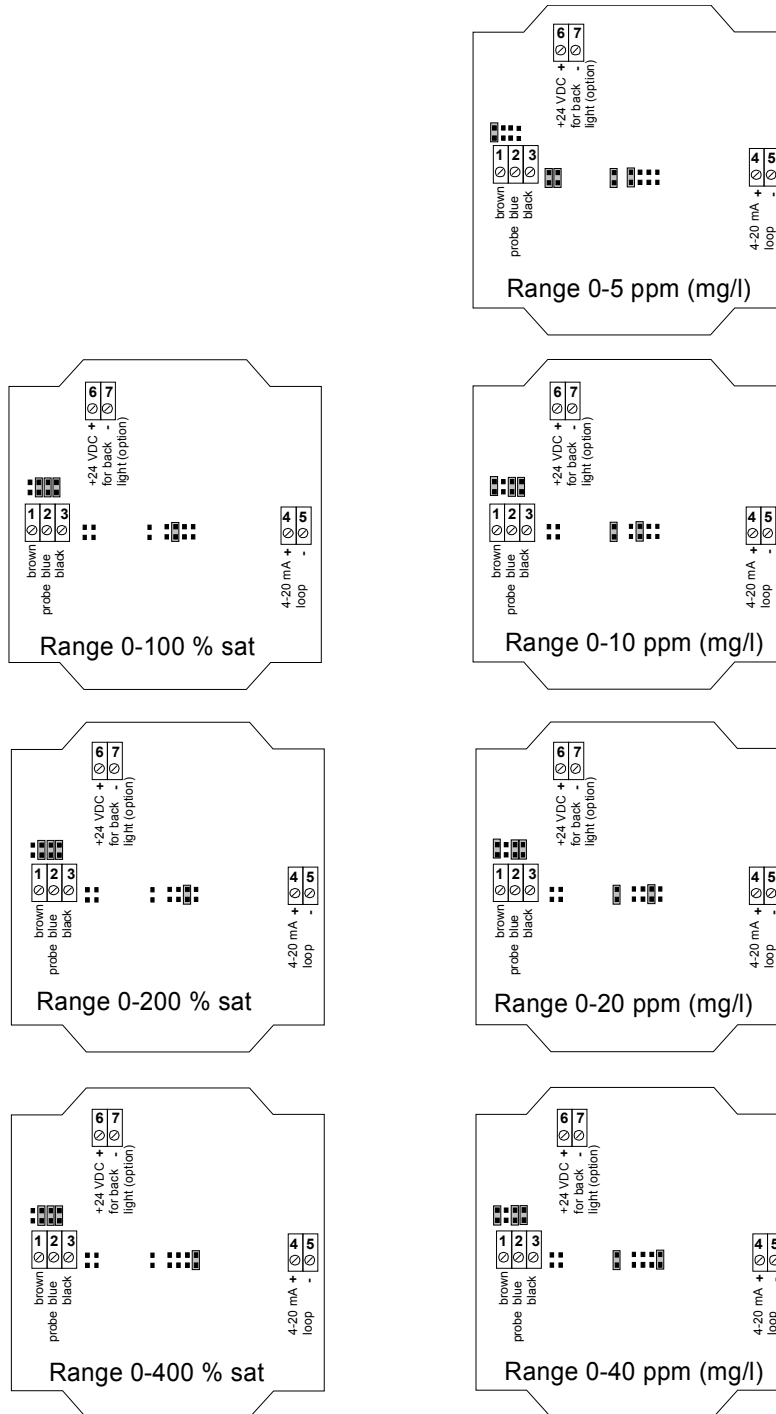

## Installation

### Physical Installation

The 840 Transmitter is easy to install. Mount the probe where there is suitable movement in the water. Approx. 1 cm/sec is sufficient at 7 ppm and a temperature of 13°C. Do not locate it where it can move and strike against the wall of the tank or other fixture, do not locate it directly over diffusers or similar. Use of the Pioneer mounting fixture is recommended when measuring in dirty water - Partech also manufacture other probe mounting fixtures, please see consult your usual sales contact.

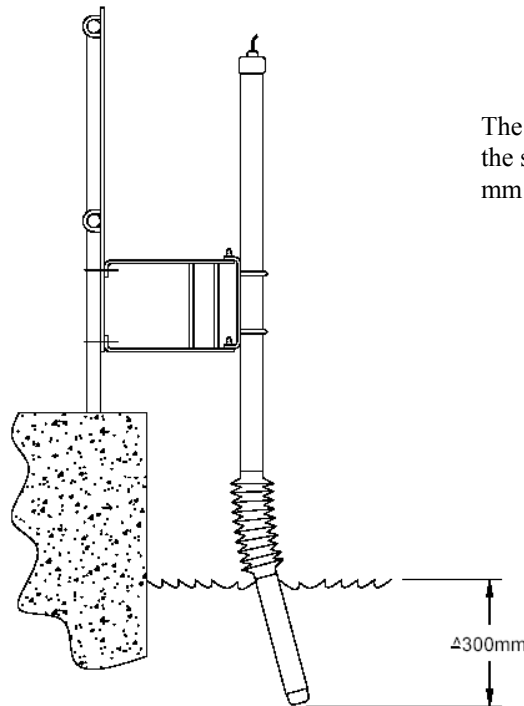

The transmitter should be fixed in a suitable position near the probe. A cover to protect it from direct rain and direct sunlight is recommended.

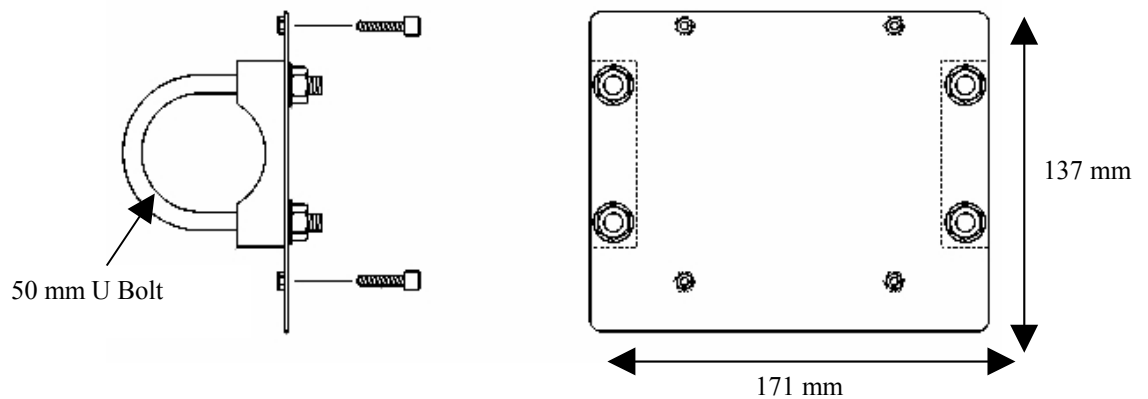

Transmitter Mounting Bracket: P/N171840

### Electrical Installation

Electrical connection is very simple; connect the 840 Transmitter in series with a power supply of between 15 and 35 volts DC and any secondary instruments desired, as shown. Use the junction box provided.

### Connection Example

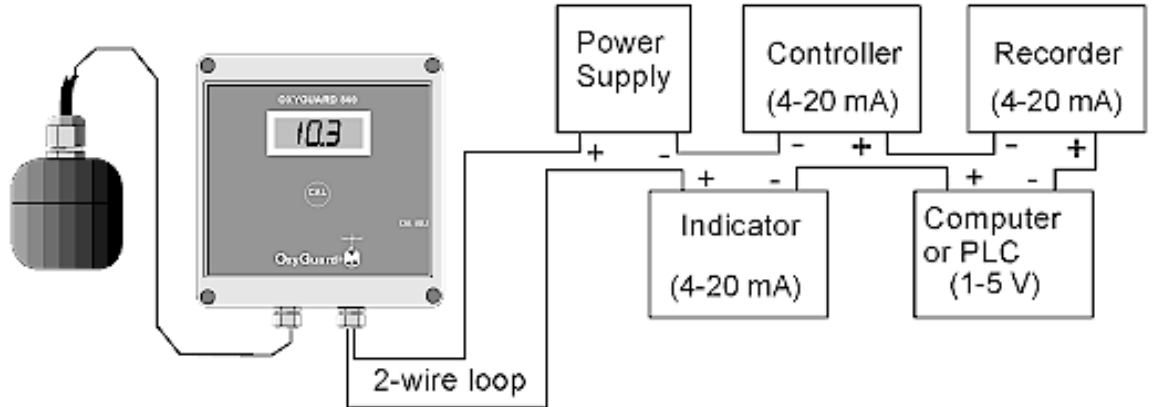

The 840 Transmitter is designed for use with circuits from 15 VDC and 50 Ω and 35 VDC and 1050 Ω. The chart shows the safe operating area, the total loop resistance must include the cable.

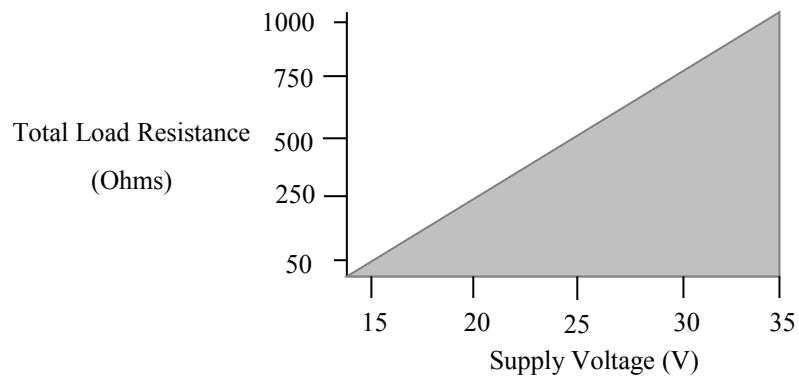

## Calibration

Calibrate carefully; no measurement is more accurate than the calibration. To calibrate place the probe in air or air-saturated water and adjust the 840 Transmitter accordingly. The probe must have the same temperature as the air or water it is calibrated in. The fastest and most accurate calibration is obtained by using the EasyCal since this establishes air-saturated conditions with the probe in its normal working position in the water. The probe is not subjected to a temperature change, and calibration takes place at the same temperature at which measurements are made.

To calibrate in air take the probe from the water, wipe the membrane dry, and hang the probe in free air in the shade (or wrap aluminium foil around it). You must now allow it to adjust to the air temperature. Any rugged, long-life oxygen probe like the 840 can take up to an hour to equalize a 10°C temperature change in air. Equalizing such a change only takes 10 minutes in water. When temperature equalization has taken place and the display is stable press the "CAL" button, then adjust the "CAL ADJ" adjustment screw (trimmer) on the side of the 840 Transmitter until the display shows the calibration value. Note that sometimes the air temperature can change so quickly that it can be very difficult to achieve temperature equalization.

Pressing "CAL" starts a 7-minute timer. During this time the 840 Transmitter switches to measure in % saturation - and with the probe in air or air-saturated water the display and loop current will correspond to 100% saturation. If you are using the 0-5 ppm range the unit also switches amplification so that the display will indicate 50.

**Calibration Value for % Sat Measurement = 100**

**Calibration Values for mg/l Measurement in Fresh Water for 10,20,and 40 mg/l ranges**

Altitude (m)	-400	-200	<b>0</b>	200	400	600	800	1000
mm Hg	800	780	<b>760</b>	741	723	705	687	671
Cal. Value	105	103	<b>100</b>	98	95	93	90	88

**Calibration Values for mg/l Measurement in Fresh Water for 5 mg/l range**

Altitude (m)	-400	-200	<b>0</b>	200	400	600	800	1000
mm Hg	800	780	<b>760</b>	741	723	705	687	671
Cal. Value	53	51	<b>50</b>	49	48	46	45	44

**Calibration Value for mg/l Measurement in Salt Water for 10, 20 and 40 mg/l ranges**

Salinity, ppt	5	10	15	20	25	30	35
Cal value	97	94	91	88	86	83	81

**Calibration Value for mg/l Measurement in Salt Water for 5 mg/l ranges**

Salinity, ppt	5	10	15	20	25	30	35
Cal value	48	47	46	44	43	42	40

NB. If you calibrate to a value other than 100 (50 for 0-5 range) only the mg/l value will be correct.

## EasyCal

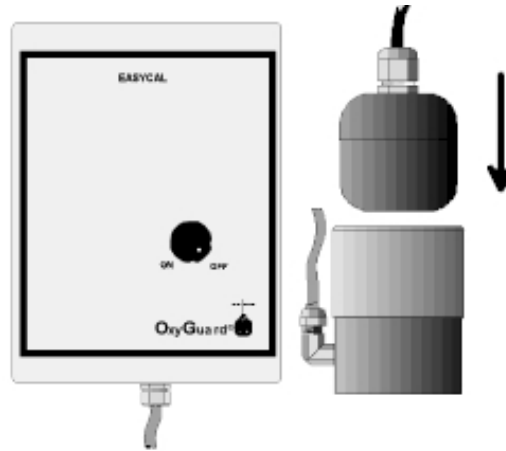

To use the EasyCal, lift the probe from the water, wipe the membrane, fit the EasyCal, return the assembly to the water, switch the EasyCal on and, as soon as the display is stable, press "CAL" and adjust the 840 Transmitter to the calibration value.

The unit will automatically revert to measure in ppm after the 7 minutes. You can also stop the timer by pressing "CAL" a second time.

## Maintenance

The 840 Transmitter needs less attention than any other oxygen probe, and the most important "direction for use" is LEAVE IT ALONE! After installation it must be calibrated, but then it will function for many years completely without attention. The best accuracy is obtained if the membrane is kept clean, but the 840 Transmitter has been designed to be very tolerant to the build-up of deposits on the membrane. To clean the membrane, wipe it with a cloth or soft paper. If desired a calibration check can be performed after cleaning the membrane. The optimal cleaning and calibration check frequency will always depend on the actual conditions.

The probe should not be taken apart unless the membrane is damaged or unless, after long use (some years), you cannot calibrate up to the correct value.

To replace the membrane and/or renovate the probe proceed as follows:

- 1) Take the probe out of the water, rinse it and unscrew the cap. If it sticks, tap the side of the probe gently with a hammer then try again. Discard the electrolyte; rinse the cap and top part, clean off any brown or black oxide deposits.
- 2) Inspect the anode. If very corroded the anode can be replaced. Check that the nut under the anode is tight before fitting a new anode. Wash the anode in soapy water before use to remove any protective oil.
- 3) Check the cathode and remove any deposits using the grey plastic abrasive pad supplied with the probe or a little wet or dry emery paper, grade 600. The cathode **MUST NOT BE POLISHED**.
- 4) Rinse and dry the top part.
- 5) You can at this stage perform an easy check on the probe. Dry the probe – especially the cathode and area around it - completely, then observe the output signal – the probe should have zero output (less than 0.01 mV when measured at the probe). Contact your distributor if this is not the case.
- 6) Fill a new (or renovated) cap to the brim with electrolyte – the excess electrolyte helps remove any air bubbles. Locate the flat machined from the thread. Lower the upper part into the cap and turn the cap half a turn to engage the thread. Tilt the probe 15° so that the flat is uppermost and screw the cap onto the top. Excess electrolyte and air should dribble out of the flat.

The probe must be filled completely. Shake it close to your ear. If you can hear the electrolyte splashing around inside it open it, re-fill it and try again.

**WHEN YOU ARE CERTAIN THAT THE PROBE IS FILLED COMPLETELY TIGHTEN THE CAP HARD.**

After renovation the probe can be regarded as new. It should be hung up in air to stabilize for at least an hour before calibration. If possible re-calibrate after a day or two.

A new membrane can easily be fitted to the cap - see the drawing. The membrane must be flat - if it wrinkles remove it and try again with a new one. It is important that all parts are clean and dry. Neither O-ring nor membrane can be used more than once.

Note that the membrane is so tough that it should never be damaged due to normal use.

Spares are included with the unit.

It is not recommended to fit a cap with a membrane that has been used before. The membrane beds in with the cathode and is stretched a little. It will not fit perfectly a second time.

**Membrane replacement:**

1) Unscrew ring, discard used membrane and O-ring

2) Thoroughly clean and dry ring and cap

Ring  
Membrane  
O-Ring

3) Place new O-ring and membrane in cap. Make sure that they are concentric in the bottom of the recess, then screw ring into place

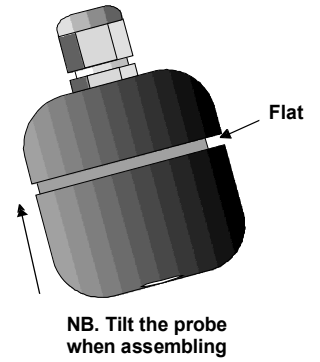
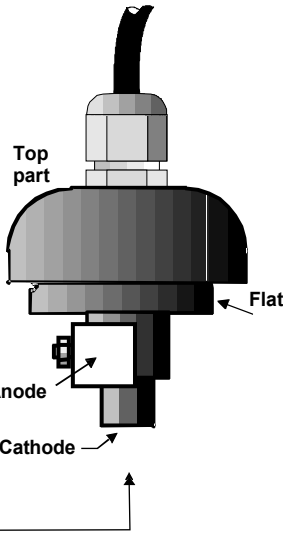
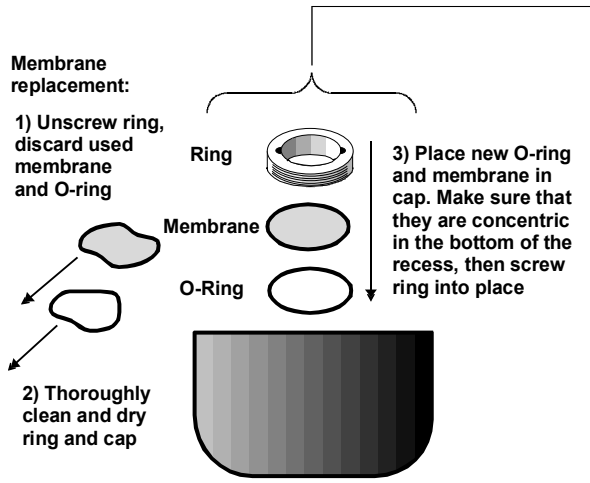

## Spare Parts

174620	Cap with Membrane and 50 ml Electrolyte
174630	Membrane Cap with Membrane
174780	10 Membranes and O-Rings
174700	500 ml Electrolyte
174690	1 litre Electrolyte
174820	Membrane Protector
171840	Handrail Mounting Bracket
185990	Instruction Manual
174450	Pioneer Probe Holder, 1.5 metre Top Section
160000	Standard Mounting Bracket
160080	Handrail Mounting Bracket

## Technical Specification

<b>Probe Dimensions</b>	Diameter = 58 mm Length = 56 mm.
<b>Control Box Dimensions</b>	121 x 119 x 60 mm.
<b>Principle of Measurement</b>	Galvanic cell, self-polarizing, fully temperature compensated.
<b>Operating Conditions</b>	0 to 40°C
<b>Minimum Flow Requirement</b>	Dependent on DO and temperature, typically 1 cm/sec.
<b>Loop Power Supply</b>	Min. 15 VDC (max 50 ohm in loop) Max. 35 VDC (max 1050 ohm in loop).
<b>Input/Output Isolation</b>	1000 V RMS input/output.
<b>Range</b>	Part Number 174100: 0-5 mg/l (ppm); Part Number 174110: 0-10 mg/l (ppm) or 0-100%Sat Part Number 174120: 0-20 mg/l (ppm) or 0-200%Sat Part Number 174130: 0-40 mg/l (ppm) or 0-400%Sat
<b>Accuracy</b>	Error less than +/- 2% of actual value when calibrated using the EasyCal or when measuring temperature is the same as calibrating temperature (barometric pressure unchanged). The probe has true zero.
<b>Response Time:</b>	90% of end value within 2 minutes.
<b>Delivery Comprises</b>	840 Transmitter with Probe, 10 m cable, 840 membrane set, 50 ml electrolyte, and O-Ring

## Technical Support

Technical Support is available by phone, fax, or email, the details of which are shown below.

Phone: +44 (0) 1726 879800

Fax: +44 (0) 1726 879801

Email: [sales@partech.co.uk](mailto:sales@partech.co.uk)

Website: [www.partech.co.uk](http://www.partech.co.uk)

To enable us to provide quick and accurate technical support please have the following information ready when you contact our Technical Support Engineer:

Monitor type, and serial number.

Sensor type, and serial number.

Application details.

Description of fault.

### **Returning Instruments for Repair**

If equipment needs to be returned to Partech for repair or service the following address should be used:

SERVICE DEPT.

PARTECH (ELECTRONICS) LTD

CHARLESTOWN

ST AUSTELL

CORNWALL

PL25 3NN

UNITED KINGDOM

Please include the following information with the returned equipment. Also ensure that sensors are adequately protected for transportation (Advice on packing can be provided by our service department).

Contact name and phone number.

Return address for equipment.

Description of fault or service required.

Any special safety precautions because of nature of application.