



SludgeWatch Ultra

Sludge Blanket Interface Monitor

PRODUCT DATASHEET

APPLICATIONS

Final Settlement Tanks
Primary Settlement Tanks
Clarifiers
DAF Thickeners
Industrial Process Thickeners

FEATURES

Automatic Self Cleaning Transducer
Single or Dual Channel Monitoring
Easy Set Up Menu System

BENEFITS

Early Warning of Blanket Failure
Automatic De-Sludging
Load Balancing of Settlement Tanks
Improved Sludge Quality

ALTERNATIVE PRODUCTS

SludgeWatch 715
ASLD 2200
8100
8200

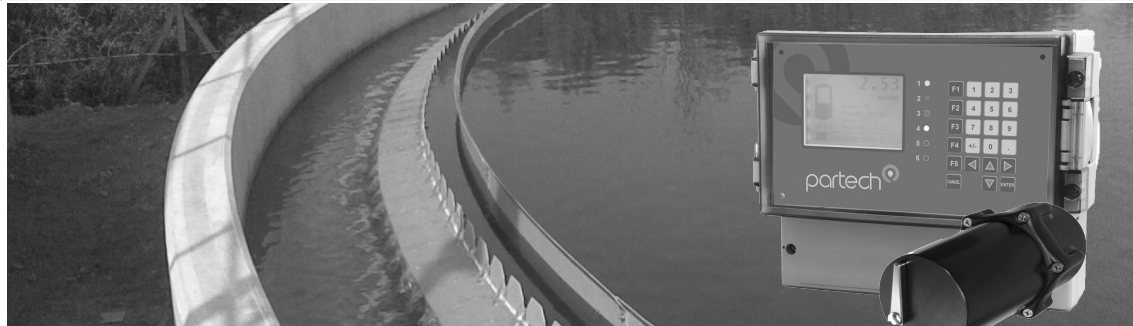

The SludgeWatch Ultra utilises the industry accepted look down ultrasonic or 'sonar' method of detecting and tracking the interface between sludge and water in water, wastewater and industrial effluent settlement tanks and clarifiers. The easy to use system has been specifically designed for these applications and makes use of an easy drop down menu structure to allow hassle free site configuration.

The self-cleaning transducer can monitor the interface in applications where the sludge has a density of 0.5% or more. The cleaning wiper operates automatically to remove dirt and air bubbles that can interfere with the measurement.

By monitoring the position of the sludge/water interface the user can make process adjustments to ensure that their plant is operating at the optimum efficiency whilst ensuring that water quality is preserved. If a blanket is allowed to rise too high in the tank there is a danger of carry-over to the effluent channel or the next processing stage, additionally strain may be placed on the scrapper mechanism. If there is too little sludge in the tank the settling process cannot work effectively, this leads to problems with sludge processing, returned sludge concentrations and again carry-over to the effluent channel.

Automated sludge blanket detection removes the need for time consuming manual checks, ensuring reliable process control everyday and during unexpected weather or load conditions.

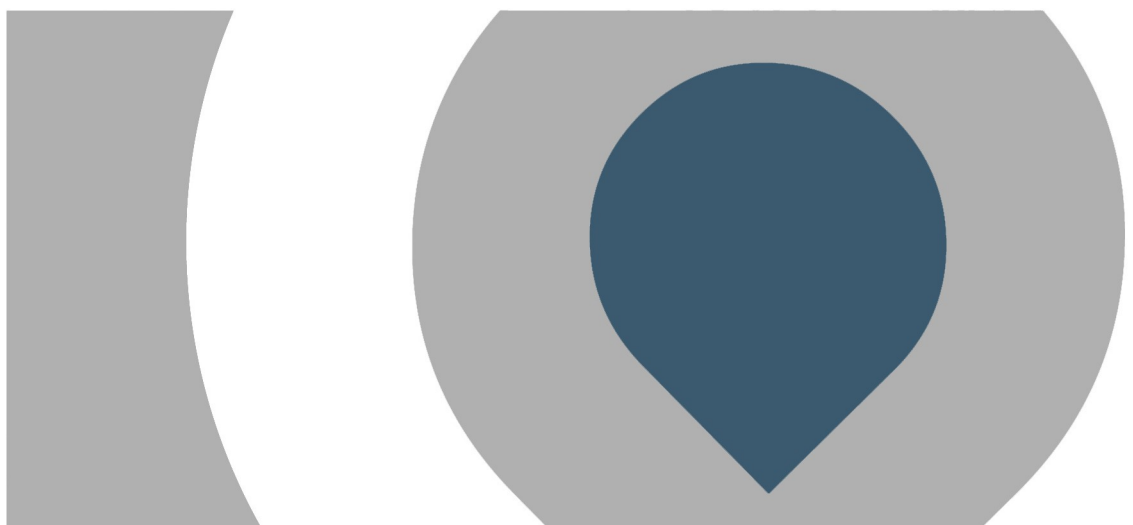

Call us on + 44(0)1726 879800 www.partech.co.uk





SludgeWatch Ultra

Sludge Blanket Interface Monitor

PRODUCT DATASHEET

SludgeWatch Ultra Monitor

The monitor provides all the setup and diagnostic information required to get the best performance out of the system.

The screen image shown to the right demonstrates the depth of information that is provided. Typically a monitor that is showing a wide 'gate' is indicating that the settlement process is not functioning well.

Advanced echo processing algorithms used allow the monitor to cope with variations in sludge density, material that is floating in the tanks and moving scrapers arms.

The monitor can operate two transducers, allowing two tanks to be controlled from a single system.

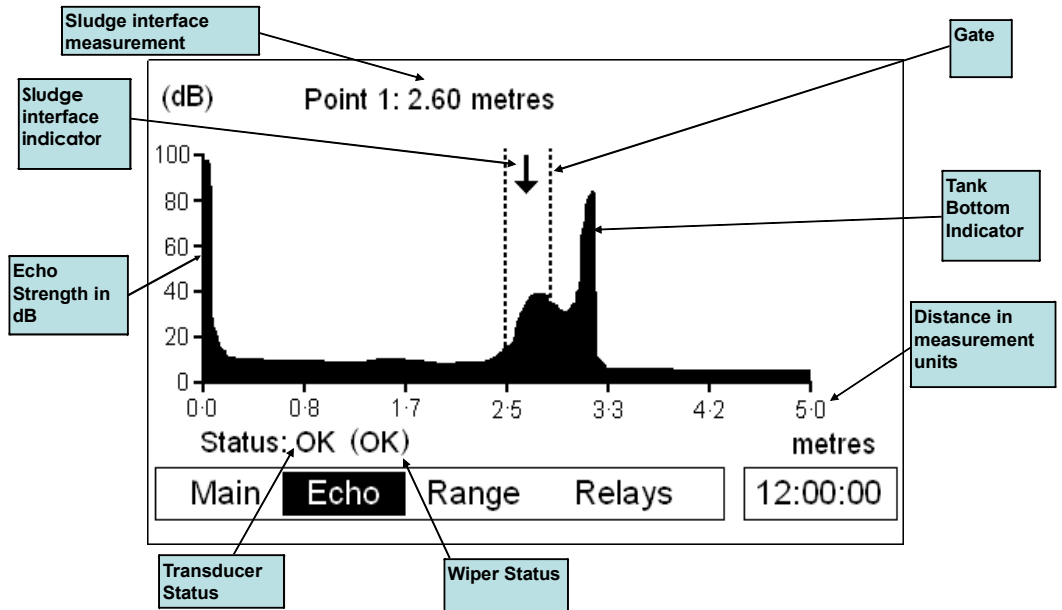

Why Monitor Sludge Blanket Level?

Any settlement process will benefit from the ability to react to changes in the behaviour of other treatment stages and to fluctuations in the load to a works. Benefits include reduced operator involvement, reduced chemical use, better sludge quality, and better control of returned activated sludge.

Why not use a Timer?

Timers cannot cope with un-expected changes in process conditions caused by rain or plant failure.

Will it save me Money?

Yes, savings will be made in reduced operator involvement, more efficient processing of sludge in digester and thickeners and reduced wear and tear on the plant infrastructure.

Call us on + 44(0)1726 879800 www.partech.co.uk



SludgeWatch Ultra

Sludge Blanket Interface Monitor

PRODUCTION SPECIFICATION

Monitor Dimensions

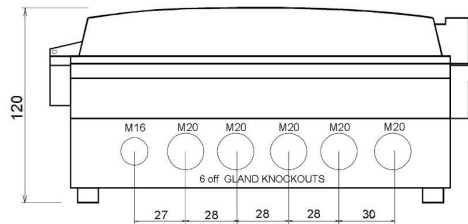
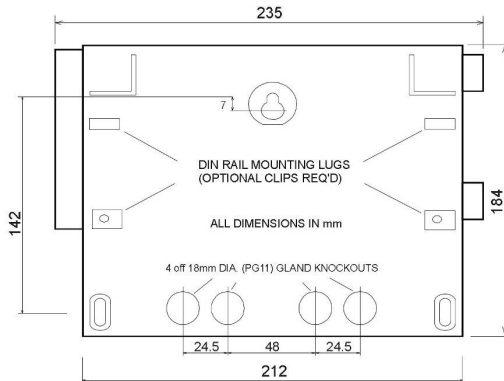

Transducer Dimensions

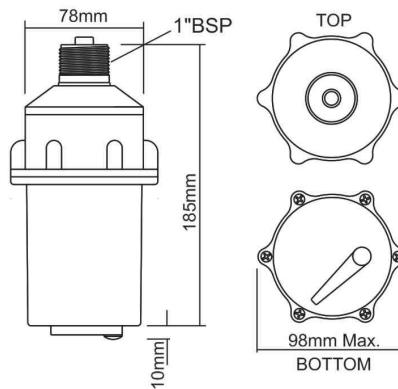

Mounting Brackets

The transducer needs to be mounted in a secure location just under the surface of the settlement tank. This can easily be achieved using the mounting equipment we offer.

Where the transducer is to be installed on a fixed bridge with an independently rotating scraper a flexible joint can be incorporated into the mounting shaft. This will allow the scraper to move the transducer out of the way as it moves slowly past.

Self Cleaning Transducer

The SludgeWatch Ultra transducer incorporates a fully automatic cleaning blade. Cleaning of ultrasonic sensors in sludge blanket monitoring applications is vital to ensure that air bubbles and debris does not build up on the transducer surface.

The cleaning mechanism on our transducer has a 0.2 mm clearance between the blade and transducer face, this avoids wear on either surface increasing the life of the system.

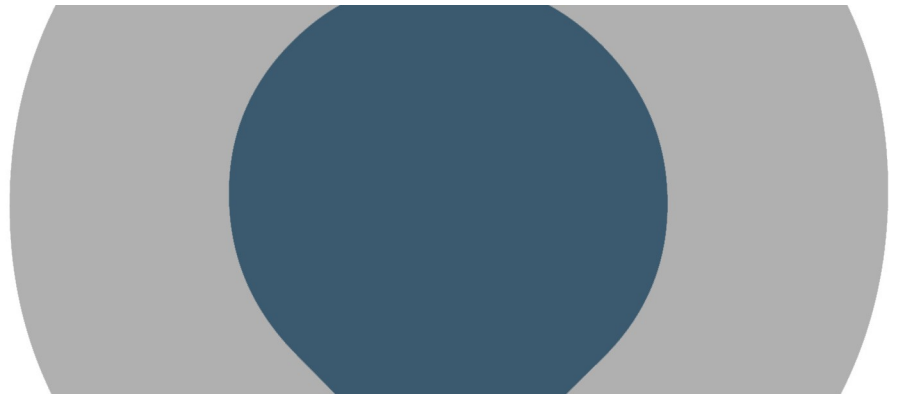
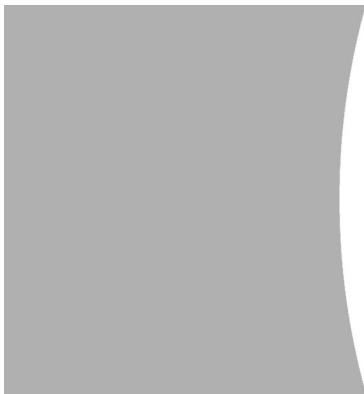



SludgeWatch Ultra

Sludge Blanket Interface Monitor

PRODUCT SPECIFICATION

Physical

Dimensions (WxHxD)
Monitor Enclosure Material
Transducer Material
Weight
Protection Class
Operating Temperature

235 x 184 x 120 mm
Polycarbonate, Flame Resistant to UL94-5V
Black Valox 357 with a 316 Stainless Steel Wiper Blade and Shaft
1 kg
IP65
-20 to 50 °C

Electrical

Supply

Rating
Cable Entry
Cable Length

100 to 240VAC 50/60Hz
22-28VDC
14W maximum, typical 11W
Cable entry knock outs, 5xM20, 1xM16 in base. 4xPG11 at rear
10 metres standard, 200 metres maximum

Measurement Details

Accuracy
Resolution
Maximum Range
Minimum Range

0.25% of the measured range or 30 mm (whichever is greater)
0.25% of the measured range or 10 mm (whichever is greater)
10 metres
0.3 metres

Outputs/Interfaces

Analogue
Relays
Relay Type
Relay Rating
Communication Bus

2 off isolated outputs 0/4 to 20mA maximum load 1000 ohm
6
C Form (SPDT)
5A at 240VAC
RS485 Modbus RTU/ASCII or PROFIBUS DPV0 or VI

User Interface

Display

Keypad
On Board Programming
PC Programming
Programming Security

192 x 128 pixel illuminated graphical display

Integral Keypad with menu navigation keys
via keypad
via RS232, RJ11 port
via user selectable passcode

Order Codes

| Part No | Description |
|---------|---|
| 224290 | SludgeWatch Ultra Monitor (100-240VAC, 2 x 0/4-20mA Output, 6 x Relay Outputs) |
| 224291 | SludgeWatch Ultra Monitor (100-240VAC, PROFIBUS DPV1 Output, 6 x Relay Outputs) |
| 224292 | SludgeWatch Ultra Transducer (Cable Length: 10 metres) |
| 224293 | SludgeWatch Ultra Transducer (Cable Length: 20 metres) |
| 224294 | SludgeWatch Ultra Transducer (Cable Length: 30 metres) |
| 223444 | SludgeWatch Ultra Transducer (Mounting Bracket Assembly, Shaft 2.5 metres) |
| 223442 | SludgeWatch Ultra Transducer (Mounting Bracket Assembly, Shaft 3.0 metres) |
| 223445 | SludgeWatch Ultra Transducer (Mounting Bracket Assembly, Shaft 3.5 metres) |

Publication No: I32382DS-Iss02
The company reserves the right to alter the specification without prior notice. E&OE

Call us on + 44(0)1726 879800 www.partech.co.uk

